



Kronz BEAMDYE®

BEAMDYE®
HT Beam Dyeing & Bleaching Machines



COMPANY PROFILE

KTM Krantz company history review 3

MACHINE DETAILS

HT beam dyeing machine BEAMDYE® 4

working principle 5

technical details 6

technical data 7

machine views 8

preparation tank 10

electrical control panel 11





Hermann Krantz - founder of the company

KRANTZ .. this name stands for over 135 years of industrial history.

In the westernmost city in Germany, Aachen, close to the borders with the Netherlands and Belgium, engineer Hermann Krantz founded the company in 1882. After initially focusing on ventilation and heating systems, textile machines quickly became another strong pillar of the company. As early as the 1920s, the company was not only supplying German textile companies but was already active worldwide. Since then, the name Krantz has been synonymous with high-performance and high-quality machines in the field of finishing and discontinuous dyeing.



dyeing machine for crosswound bobbins, 1931

In 1992 the Krantz family decided to sell the company to the Deutsche Babcock Group. As part of the subsequent realignment of the company, the production of the dyeing machines was outsourced to an independent subsidiary in Turkey. Here, of course, great importance was attached to ensuring that the old quality standards were fully guaranteed. Today the company is part of the ProTeknik group and is continuing the more than 100-year success story of the original German company.



HT beam dyeing machine BEAMDYE®

KRANTZ goes green ... Strong words for a strong and successful performance!

In these times, the world of dyeing and finishing textiles is facing enormous ecological challenges. Enormous increases in the costs of electricity, water and wastewater treatment as well as the legitimate pressure to conserve resources are forcing textile dye houses to rethink efficiency and production steps.

The new **BEAMDYE®** with its increased productivity and enhanced reliability, offers complete new perspectives and possibilities for all progressive textile dyeing and finishing mills worldwide.

The machine is the excellent result of more than 4 decades of experience in HT beam dyeing technology and is suitable for:

- dyeing
- bleaching
- washing



KRANTZ Beam dyeing machines are in operation in more than 75 countries. KRANTZ HT beam dyeing machines can be supplied for capacities from 10 up to 7.000 m, a max. operating temperature of 140° C and a liquor ratio starting at 1:4 up to 1:6.

KRANTZ goes green...go with us and get be inspired...





Working principle BEAMDYE®

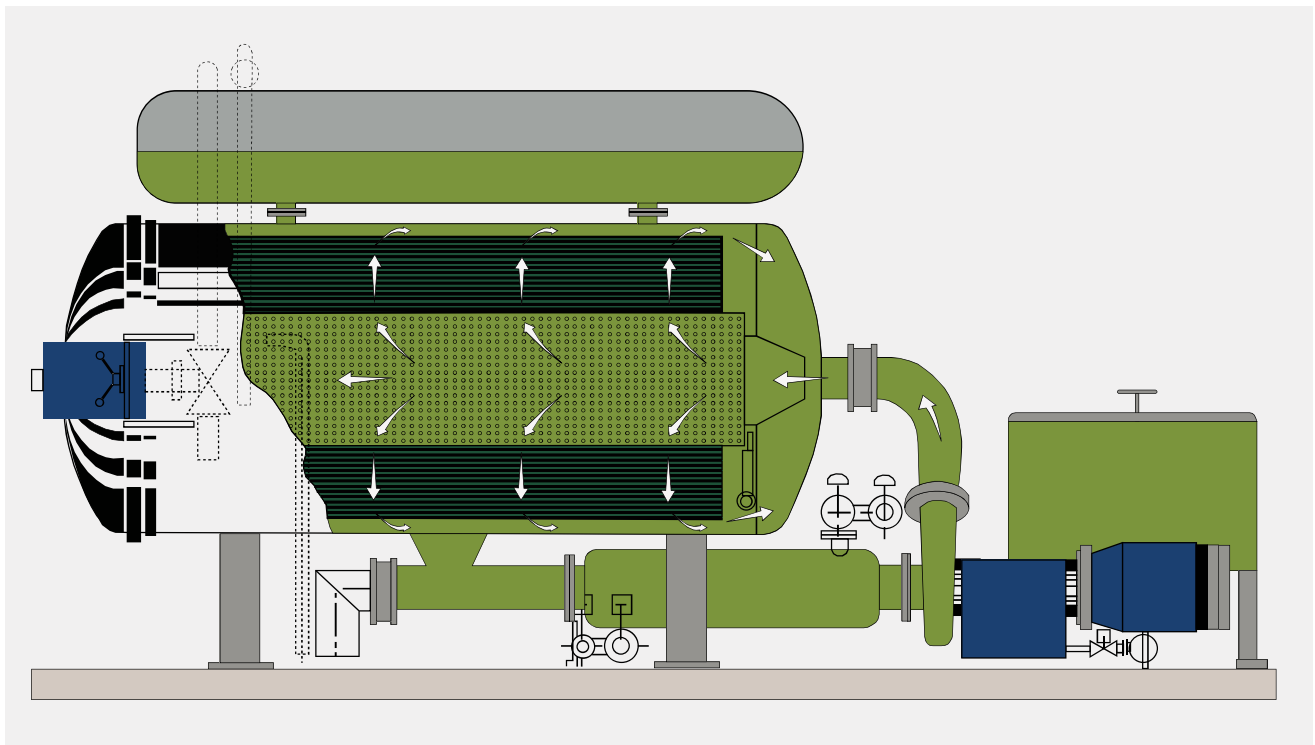

Kranz BEAMDYE-B-HT® liquor circulation dyeing dye process

Beam dyeing machines are used for all types of fabric including wovens and knits made of all kinds of fibers and blends. They are particularly suitable for non-structural fabrics permeable to water, in addition to the advantage of crease-free dyeing. Outstanding results are achieved above all with home textiles, PES curtains as well as with warp knitted fabrics.

We are able to deliver machines with a diameter starting from 210 mm up to 1600 mm and a beam length up to 3.800 mm, as single or double beam design. As a standard the machine is coming with an expansion tank on top of the machine.

A strong in-house-made centrifugal pump with frequency controller ensures an optimal liquor flow and perfect dyeing result precisely tailored to the type of fabric to be treated. Liquor flow from inside to outside and in reverse flow as an option.



Technical details

- all parts, which are in contact with liquor are manufactured from 1.4401, 1.4404 & 1.4408 ss.
- air pad system: By decreasing the volumes it is even possible to dye at a low liquor ratio less than than 1:5 with many articles.
- analog dosing allows the addition of dye liquors and auxiliaries from the preparation tank following programmable curves for time and mode.
- the machine is designed for a max. operating pressure of 140°C and a max. operating pressure of 5bar.
max. working width of 3.800mm.
- all machine functions are controlled with a modern touchscreen controller.
- strong in-house made centrifugal pump
- lowest energy, water & steam consumption

Kanzy BEAMDYE-B-HT® technical details





MACHINE SIZES

machine sizes [Ø]	20 - 50g/m tulle				100 - 150g/m satin			
	one beam - max. 3.650mm		double beam - max. 1.600+1.600mm		one beam - max. 3.650mm		double beam - max. 1.600+1.600mm	
	min. [m]	max. [m]	min. [m]	max. [m]	min. [m]	max. [m]	min. [m]	max. [m]
210	10	100						
350	50	350	50+50	300+300	20	150	20+20	100+100
550	100	750	200+200	700+700	75	150	75+75	150+150
800	500	2.000	500+500	2.000+2.000	250	500	175+175	350+350
1.000	1.000	3.500	1.000+1.000	3.500+3.500	400	800	300+300	600+600
1.200	2.000	4.500	2.000+2.000	4.500+4.500	600	1.250	300+600	1.200+1.200
1.600	3.000	7.000	2.500+2.500	7.000+7.000	2.000	3.500		

Kronly BEAMDYE® machine loading according machine sizes



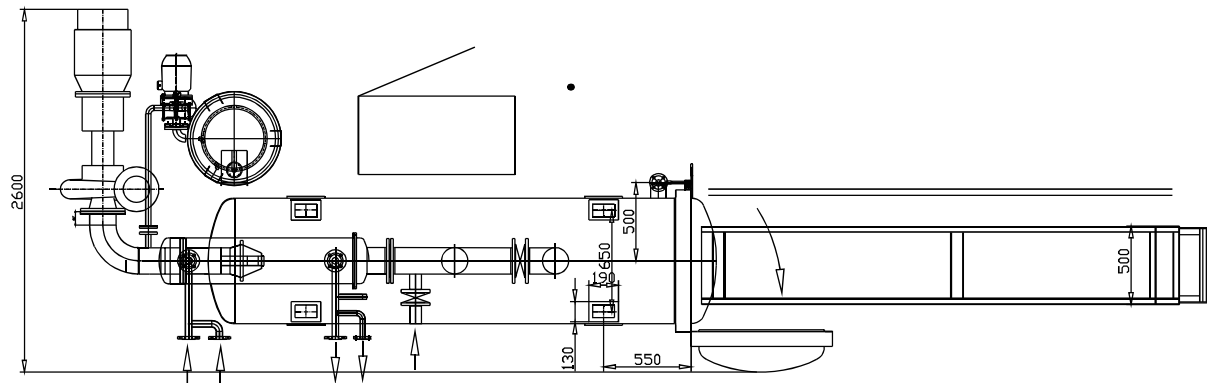
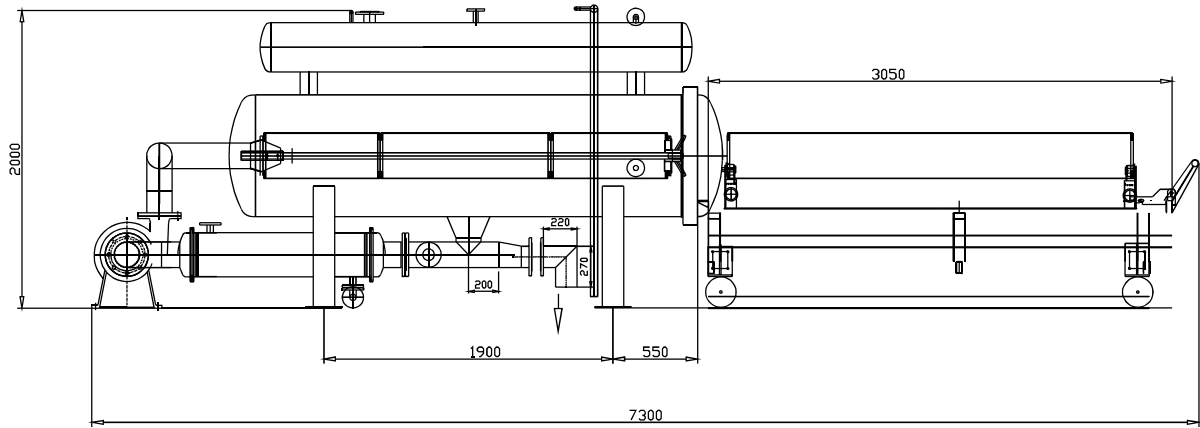

Kranz BEAMDYE-B-HT[®] technical side & top view



Kromby

WARNING
PLEASE FOLLOW THE INSTRUCTIONS BEFORE OPENING THE LOAD
1- PRESSURE MUST BECOME ZERO
2- TEMPERATURE MUST BE FOLLOW 80°C
3- WATER LEVEL MUST BE BELOW LID LEVEL
WE WILL NOT BE RESPONSIBLE FOR THE ACCIDENTS THAT WILL BE OCCUR

UYARI
KAPLI AÇMADAN ÖNCE
1- BAZIĞI SIFIR BARI GÖSTERİRDEN
2- SICAKLIĞI 80°C'İN ALTINDA OLMALI
3- SUYUN SUYU SEVİYESİ KAPLIDAN ALTINDA OLMALI
BU UYARILARA OYUNMADIKÇA TAHSİRİ OLABİLECEK KAZALARDAN
İBALETTİ FİRMA SORUMLU OĞULOR.



Preparation tank

The preparation tanks are used for the preparation of the treatment liquor bath including dyestuffs and chemicals or salt.

The tank is indirect steam heated by means of heating coils located at the ground of the tank (heating gradient is 5°C/min)

The tank is also fitted with a mixer and a level control system and cleaning automatically takes place after the dye process is finished.

The pump for the preparation tank is a reserve centrifugal-type pump.



dye bath while splash protection cover of the tank is open

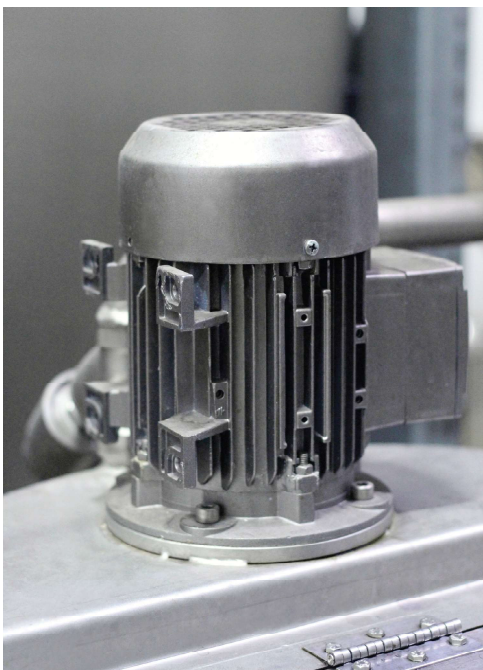

motor for mixer

Hot water tank

As an option our customers have the choice to take a separate hot water tank, same capacity as the dye vessel, which will reduce the process times by 1-1.5 hours.

Options

A wide range of options is available upon request like PH control system, additional fresh water or drain valves among others.



MACHINE DETAILS

Electrical control panel

The whole switch board & electric cabinet is made from stainless steel.

All relevant motors, electrical and electronical parts as well as inverters are exclusively sourced from first class European high-end manufacturers.

Krantz just uses high-end controllers from top manufacturers such as the Secom series from Setex or Sedomat series from Sedo-Treepoint. Other brands are possible upon request.

With these controllers, even very sophisticated automation tasks can be realized without problems. Integrating an automatic dye kitchen becomes a standard task.

Complex machines can easily and directly be operated by using the integrated touch-screen.



additional control buttons



controller SECOM series



controller SEDOMAT series



inverter





 GERMAN TECHNOLOGY
designed & developed in Germany

sales & distribution

HochstraÙe 42
52078 Aachen
Germany
T +49.241.560 002 87
F +49.321.210 914 30
E info@ktmkrantz.com

factory I

Osmangazi Mahallesi
Küçükyazma Cad. No:13/2
Esenyurt-Istanbul/TR
T +90.212.858 08 08
F +90.212.858 00 70
E info@ktmkrantz.com

factory II

Yazlik Yenimahalle
D-130 Karayolu Cad. No:87/A
41650 Gölcük-Kocaeli/TR
T +90.262.343 30 90
F +90.262.343 30 90
E info@ktmkrantz.com